



500GAL Decarbonator Specification Sheet

Product Description

The DECARBONATOR® is a high-performance appliance designed for commercial kitchens and bakeries to efficiently remove carbon buildup and grease from metal and aluminum kitchen equipment. Constructed from stainless steel, it is fully insulated and provides the most cost-effective and efficient method for deep cleaning kitchen equipment and accessories. It is a stand alone unit that requires no plumbing.

Technical Specifications

Specification	Details
Voltage	208/220V
Amps	28A
Frequency	50/60Hz
Phase	Single
Plug Type	NEMA 6-50
Receptacle	NEMA 6-50
Breaker	50 Amp
Wattage	6750W
Operating Temp	185°F (85°C)

Capacity & Dimensions

Measurement	Details
Volume	500 Gallons / 1890 Liters
Sheet Pan Capacity	416 stacked vertically
Hood Filter Capacity	120 Standard (20" x 20" x 1½")
Baking Rack	Double Baking rack horizontally
External Dimensions	L-88" x W-53" x H-46" (224cm x 135cm x 117cm)
Internal Dimensions	L-76" x W-42" x H-36" (193cm x 107cm x 91cm)
Packaging	L-92" x W-54" x H-53" (233cm x 137cm x 134cm)
Gross Weight	1460 lbs (664kg)
Net Weight	1360 lbs (618kg)

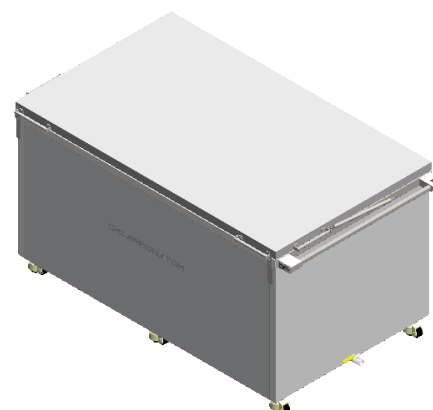
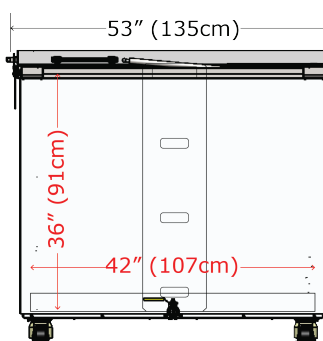
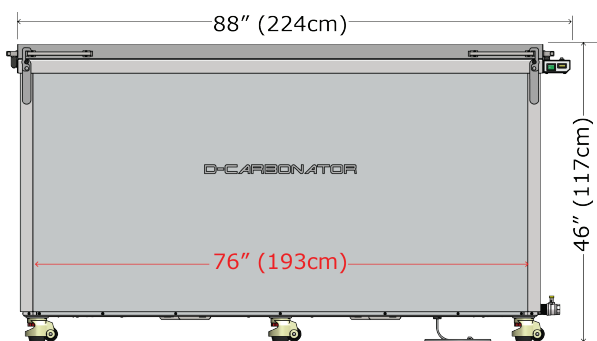

CarbonZyme®

CarbonZyme 50lbs	Four boxes per month
------------------	----------------------

Accessories Included

Accessory	Description
Lifting Basket	Facilitates loading and unloading
Drain Hose and adaptor	Used for draining tank
Grab Hook	Used to lift items and dislodge debris blocking drain valve

Special Features

Features	Description
AGC500 Adj Gantry Crane Electric motor hoist	Optional add on hoist
Baking Rack cleaner	Fits double baking rack
Basket frame	Optional add on individual basket with frame

Key Features

Feature	Description
Friction Hinges	Allows steam to escape, prevents crush injuries
Fill Line (Embossed)	Easy water level identification
Lid with Gasket	Reduces odors, collects condensation, adds workspace
Lid Handle	Full-length for easy lifting, prevents wrist scalding
Velcro Strap Storage	Stores power cord and drain hose securely
Stainless Steel Casters	Two locking, two non-locking for mobility
Control Panel Indicators	Power, heater, monthly timer, reset switch
Troubleshooting Feature	Manual reset thermostat on back panel

Benefits

Benefit	Description
Fast & Efficient Cleaning	Saves time and effort in deep cleaning kitchen equipment
Energy Efficient	Low power consumption with high performance
Durable Stainless Steel Build	Long-lasting and corrosion-resistant
Safety First	Designed to prevent injuries and operational hazards

Certifications & Compliance

Certification	Details
SA44909 - Sanitation NSF/ANSI 169 Certified	Ensures food safety standards. Meets sanitation regulations
E495028 - Commercial Dishwasher Safety Listing	Certified safe for commercial kitchen use
FY160801691C - European Conformity Safety Listing	Certified safe for commercial kitchen use

Contact Information

Company: ChemXworks

Address: 8952 AleSmith Ct, Ste D, San Diego, CA 92126



Phone: (858) 356-5460

Website: www.decarbonator.com