

DECARBONATOR™

NEXTGEN COMMERCIAL KITCHEN CLEANING APPLIANCE



HEATED SOAK TANK
ELIMINATE SCRUBBING



SUSTAINABLE



SAVE MONEY



SAVE WATER



SAVE TIME



BEFORE



AFTER

ABOUT US

Founded in 2012, Dr. Gary Shifren, inventor of the DECARBONATOR™ and the heated soak tank technology used today, emerged with a clear mission; **We are passionate about revolutionizing the way commercial kitchens and bakeries clean and sanitize their equipment.**

Our NextGen product, the DECARBONATOR™, is a state-of-the-art heated soak tank that removes carbon build-up, grease and grime with unparalleled cleaning power. Our environmentally friendly, award-winning equipment reduces water and energy consumption, earning us recognition for sustainability. Discover how our innovative technology can transform your kitchen, your business and your operations.



WHAT IS A DECARBONATOR™?

The DECARBONATOR™ is a heated soak tank that cleans all metal cookware and kitchen equipment. **Our appliance eliminates hours of scrubbing, the worst job in the kitchen, while saving money, time, water, and energy expenses.**

- Removes Carbon Build Up
- Degreases
- Degrimes
- Cleans
- Sanitizes
- Requires NO SCRUBBING
- 5 Sizes Available
- Stand Alone Unit
- Plugs into a regular wall outlet
- No plumbing required
- Ready to Use Immediately After Set Up
- 3 Certifications



HOW THE DECARBONATOR™ WORKS

Once the tank is filled with water and with our safe, proprietary detergent CarbonZyme®, the heated tank maintains the water and detergent at an optimal temperature of 185° F [85° C].

Place your equipment into the DECARBONATOR™ and let it soak. Soaking times depend on level of build up. Initial soak time may vary yet subsequent soak times will be dramatically reduced.

- **Heavy Carbon Build Up** - Overnight Recommended
- **Hood Vent Baffles** - As Little as 20 Minutes

When equipment is removed from the DECARBONATOR™ it is **fully sanitized and bacteria free.**



EASY OPERATION & MAINTENANCE

Experience the simplicity of operating the DECARBONATOR™, a heated soak tank revolutionizing commercial kitchen cleaning by effortlessly removing carbon build-up, grease, and grime in six easy steps, requiring maintenance just once a month regardless of size, all managed by a single operator to ensure optimal condition.

STEP ONE

Fill the unit with clean hot water to the ---H2O--- line.



STEP TWO

Plug the unit into an electrical outlet and switch ON.



STEP THREE

Reset the MONTHLY TIMER.



PRO TIP: Change water & CarbonZyme® each month for optimal performance.

STEP FOUR

Add the CarbonZyme® detergent and mix with the water thoroughly.



STEP FIVE

Load the DECARBONATOR™ with equipment. Use the lifting basket to lower the items into the unit. Leave to soak.

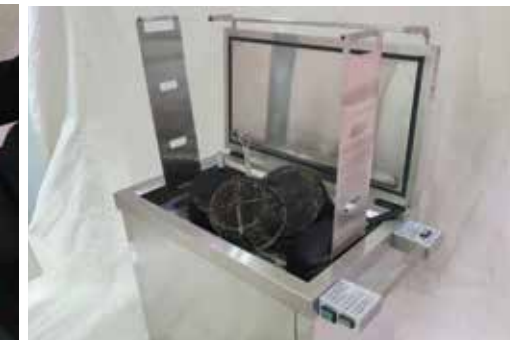

STEP SIX

Remove the items and rinse off any residue.



DISCLAIMER: ALWAYS FOLLOW YOUR OWN COMPANY'S BEST PRACTICES

CarbonZyme®

- Safe
- Non-Hazardous
- Non-Caustic
- Aluminum Safe
- Rubber Safe
- Plastic Safe
- Environmentally Friendly
- Kosher



Online Ordering : Quick & Easy

Order CarbonZyme® refills, accessories, and replacement parts for your DECARBONATOR™ in our online store.



SHOP NOW

WHAT CAN THE DECARBONATOR™ CLEAN?

Unveil the transformative power of the DECARBONATOR™ as it rejuvenates a wide range of kitchen equipment, from pots and pans, grills, filters, and burners, to full sized baking racks and more, ensuring each item stays sanitized, in optimal condition and ready to use regardless of build up level.

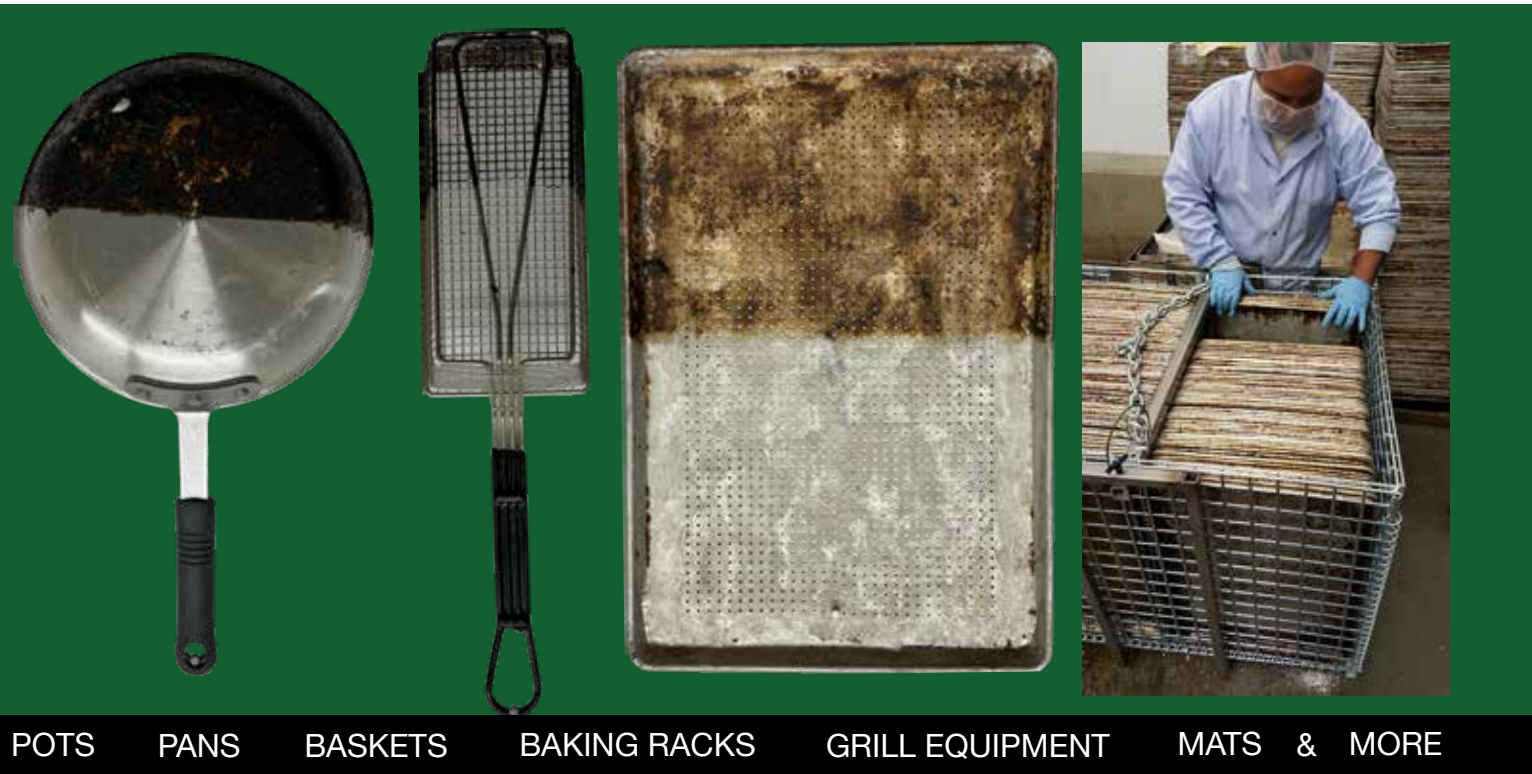

POTS PANS BASKETS BAKING RACKS GRILL EQUIPMENT MATS & MORE

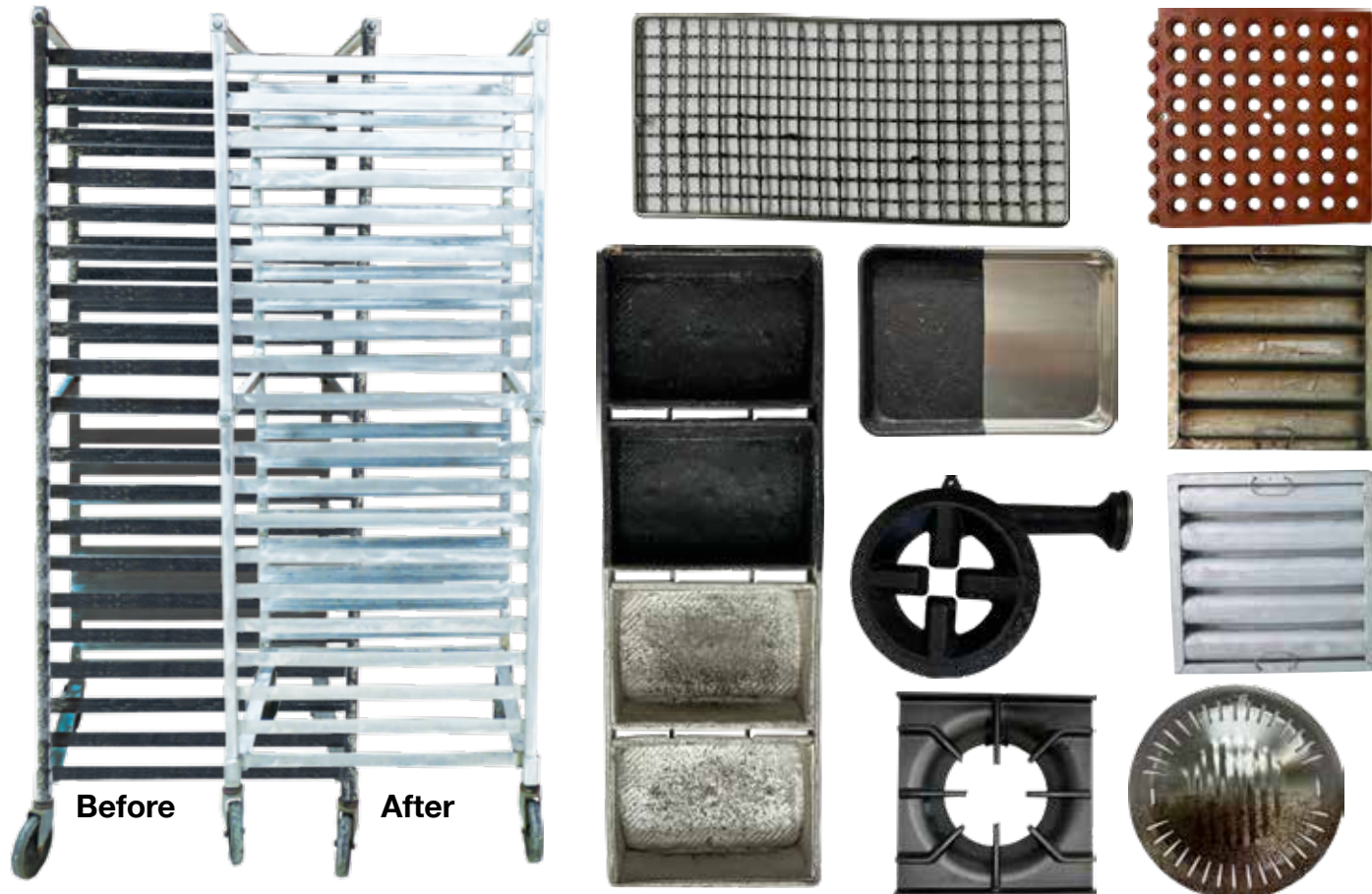

THE ULTIMATE HOOD VENT BAFFLE CLEANING APPLIANCE

Traditional methods of cleaning hood filters, whether by hand or dishwasher, fails to reach the dirt, grease and grime trapped within the baffles. The baffles serve as a sanctuary for bacteria, increases fire risk and drives up operational costs. The DECARBONATOR™ effectively cleans outside and inside the hood vent baffles, in as little as 20 minutes, efficiently cleaning every time.



CLEAN HOOD FILTER BENEFITS

- Reduces Fire Risk
- Maintains a Cool Kitchen
- Removes Airborne Grease, Grime and Dirt
- Reduces HVAC Electricity
- Saves on External Cleaning Costs
- Reduces the need for Full Hood System Cleaning

INDUSTRIES WE SERVE

DECARBONATOR™ proudly serves all commercial kitchens across the Food & Beverage, Food Manufacturing, and Bakery industries. If you have a commercial kitchen, then having a DECARBONATOR™ will change your kitchen operations forever.



ASSOCIATIONS & AWARDS



DECARBONATOR™ PRODUCT LINE

MODEL: 40GAL

VOLUME: 40 Gallon/150 Liter
Voltage: 110V/60Hz/1PH
Amps: 8.3A (15Amp breaker)
Plug: NEMA 5-15

DIMENSIONS (LxWxH)

Outside: 36" x 20" x 33"
 91cm x 51cm x 84cm
 Inside: 26" x 13" x 25"
 66cm x 32cm x 64cm

CAPACITY

Sheet Pans 26 (Stacked Horizontally)
 Hood filters 7

FEATURES: Fits under counter
CarbonZyme: 1 x 15lb Box per Month

SB SPLIT BASKET ACCESSORY (Sold Separately)

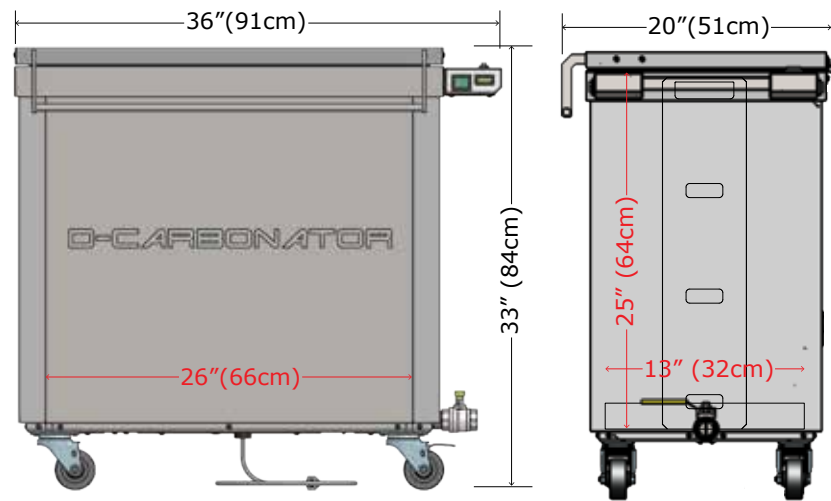

MODEL: 120GAL

VOLUME: 120 Gallon/450 Liter
Voltage: 208-220V/50Hz/1PH
Amps: 12A (20Amp breaker)
Plug: NEMA 6-20

DIMENSIONS (LxWxH)

Outside: 50" x 31" x 41"
 127cm x 79cm x 104cm
 Inside: 39" x 24" x 33"
 99cm x 61cm x 84cm

FEATURE: H120 Hoist can be fitted
CarbonZyme: 1 x 50lb Box per Month

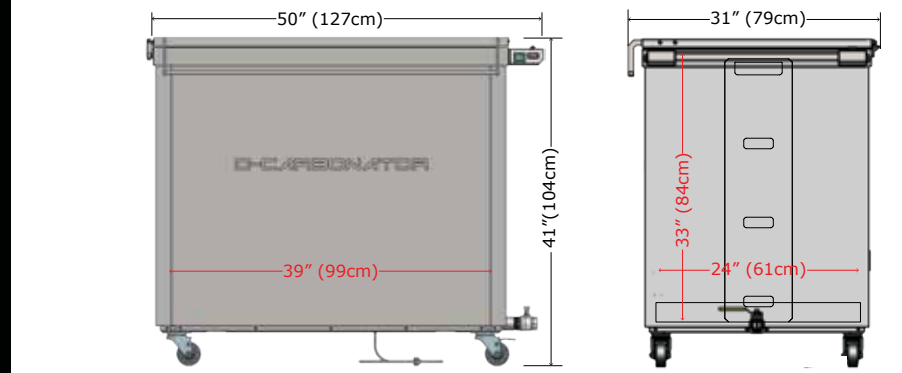

CAPACITY: 104 Sheet Pans (Stacked Vertically) | 30 Hood Filter Baffles

MODEL: 250GAL

VOLUME: 250 Gallon/945 Liter
Voltage: 208-220V/50Hz/1PH
Amps: 18A (30Amp breaker)
Plug: NEMA 6-30

DIMENSIONS (LxWxH)

Outside: 88" x 34" x 43"
 224cm x 86cm x 109cm
 Inside: 76" x 24" x 33"
 193cm x 61cm x 84cm

FEATURES: Fits Single Baking rack
CarbonZyme: 2 x 50lb Boxes per Month

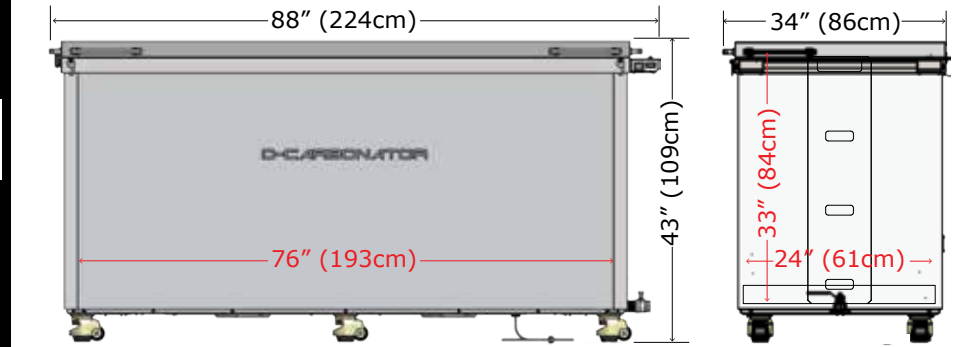

CAPACITY: 208 Sheet Pans (Stacked Vertically) | 60 Hood Filter Baffles

MODEL: 85GAL

VOLUME: 85 Gallon/320 Liter
Voltage: 110V/60Hz/1PH
Amps: 12A (20Amp breaker)
Plug: NEMA 5-15

DIMENSIONS (LxWxH)

Outside: 42" x 27" x 36"
 107cm x 69cm x 91cm
 Inside: 31" x 20" x 28"
 79cm x 51cm x 71cm

CAPACITY

Sheet Pans 52 (Stacked Horizontally)
 Hood filters 20

FEATURES: H85 Hoist can be fitted
CarbonZyme: 2 x 15lb Boxes per Month

SB SPLIT BASKET ACCESSORY (Sold Separately)

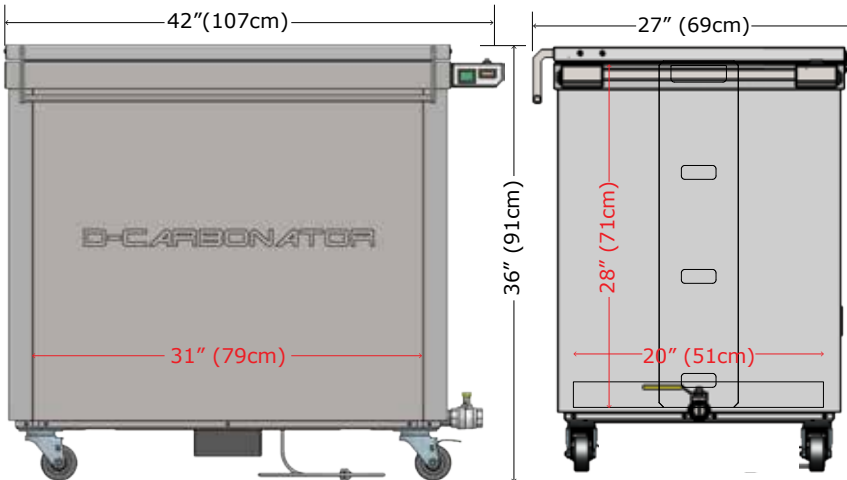

MODEL: 500GAL

VOLUME: 500 Gallon
 1890 Liter
Voltage: 208-220V/50Hz/1PH
Amps: 28A (50Amp breaker)
Plug: NEMA 6-50

DIMENSIONS (LxWxH)

Outside: 88" x 53" x 46"
 224cm x 135cm x 117cm
 Inside: 76" x 42" x 36"
 193cm x 107cm x 91cm

FEATURES: Fits Double Baking rack
CarbonZyme: 4 x 50lb Boxes per Month

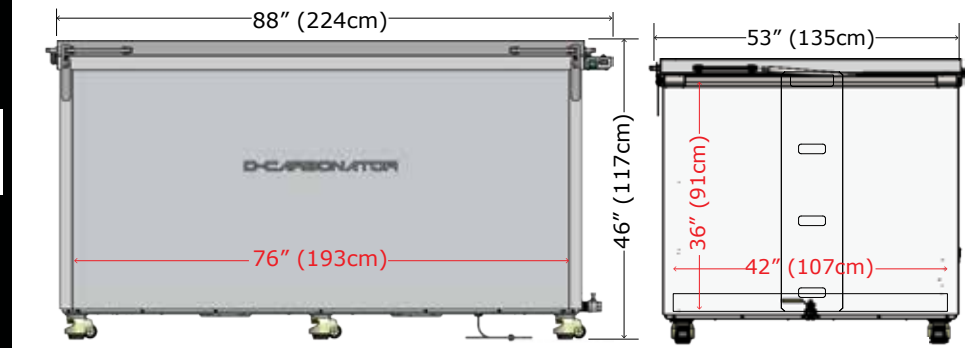

CAPACITY: 364 Sheet Pans (Stacked Vertically) | 120 Hood Filter Baffles

A ACCESSORIES

Our accessories are engineered for safety, efficiency, and productivity. Our hoists minimize strain and reduce the risk of injury, while our tools such as our gloves and hooks ensure user well-being.

HI Heat Gloves
 sku: 141000

Grab Hook
 sku: 142100



Single Person Hoist
 sku: H85



For 85GAL & 120GAL Tanks Only

H LARGE GANTRY HOISTS

Gantry Hoist
 sku: HC250

For 250GAL only



Gantry Hoist
 sku: AGC500

For 500GAL only



SB SPLIT BASKET SHOWN HERE



DECARBONATOR™

8952 AleSmith Ct, Suite D
San Diego, CA 92126, USA
decarbonator.com
858-356-5460
info@decarbonator.com

PRSR STD
US POSTAGE PAID
SAN DIEGO CA
PI 3131

THE DECARBONATOR™ DIFFERENCE



FLAT LID

Adds workspace surface area

LID HANDLE

Extends the full length
Easy to access from both sides



COLOR CODED SWITCHES

Easy Identification

RESET SWITCH (Monthly)

Indicators for optimal operation
and sanitation



LIFTING BASKET

Handles positioned above the hot
water
Wide locating bracket
Wide locating slot

CONDENSATION TROUGH : Catches condensation
RUBBER GASKET : Contains any smell
--H2O-- FILL LINE : Embossed inside the tank for easy fill



FRICTION HINGES

Prevents scalding and crushing
injuries
Prevents lid from opening too
fast
Allows steam to escape

HOSE STORAGE : Always easily accessible
TROUBLESHOOTING : Manual Reset (*No Technician Needed*)

EMPLOYEES

- Eliminates scrubbing, the worst job in the kitchen
- Improves employee morale
- Free's up employees time
- Reduces back, shoulder and neck injuries
- Restores Equipment

HYGIENE

- Cleans Equipment
- Sanitizes
- Health Inspection Compliant
- Restores Equipment

HEALTH & SAFETY

- Safe for people
- Safe for the environment
- Safe on equipment
- Non-Hazardous
- Safe on Aluminum
- Kills/Eliminates Harmful Bacteria
- Reduces Musculoskeletal Injuries



FINANCIAL

- Saves money on labor
- Saves money on chemicals
- Conserves water
- Saves money on utilities
- Saves money on cleaning equipment
- Equipment lasts longer
- Reduces heating costs
- Works 24/7
- CarbonZyme lasts one month

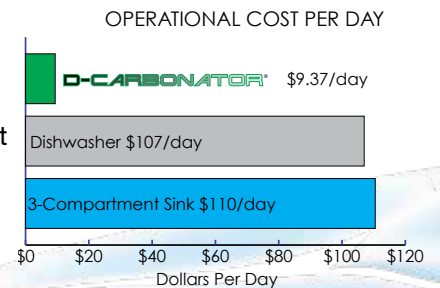

NEED ASSISTANCE?
We've Got You
Covered.



Troubleshoot
Reset Video



DECARBONATOR™
Instructional Video



Visit Our Website



Shop Now

DECARBONATOR™

NEXTGEN COMMERCIAL KITCHEN CLEANING APPLIANCE